



Sealed Lead-Acid Batteries Technical Manual

POWER  SONIC

We've Got The Power.™

Table of Contents

Features of Power-Sonic Sealed Lead Acid Batteries	1
Battery Construction	2
Theory of Operation	3 & 4
Battery Capacity	5 & 6
Battery Capacity Selector	7
Performance Data	8
Discharge.....	8
Open Circuit Voltage.....	8
Temperature	9
Shelf Life and Storage	10
Battery Life	10-11
Over Discharge	12
Charging	12
Charging Techniques Summary	13
Charging Characteristics.....	13
Charging Methods.....	13
Constant Voltage Charging.....	14
Constant Current Charging.....	15
Taper-Current Charging.....	15
Overcharging	16
Undercharging.....	16
Charging for Cycle Operation.....	16
Charging for Standby Operation.....	16
Two-Step Constant Voltage Charging.....	17
Charging in Series.....	17
Charging in Parallel.....	18
Temperature Compensation.....	18
Top Charging.....	18
Charging Efficiency.....	19
Important Do's and Don'ts	20
Handling.....	20
Installation.....	20
Charging.....	21
Notes	22
Glossary	24

Features of Power-Sonic Sealed Lead Acid Batteries

Sealed/Maintenance-Free

The valve regulated spill proof construction allows trouble-free safe operation in any position. There is no need to add electrolyte, as gases generated during the charge phase are recombined in a unique "oxygen cycle."

Power-Sonic sealed lead acid batteries can be operated in virtually any orientation without the loss of capacity or electrolyte leakage. However, upside down operation is not recommended.

Long Shelf Life

A low self-discharge rate, up to approximately 3% per month, may allow storage of fully charged batteries for up to a year, depending on storage temperatures, before charging becomes critical. *However, we strongly recommend that all batteries should be recharged within six months of receipt as it will enhance their long term life.*

Please refer to this Technical Manual and individual battery specification sheets for more details.

Design Flexibility

Same model batteries may be used in series and/or parallel to obtain choice of voltage and capacity. The same battery may be used in either cyclic or standby applications. Over 80 models available to choose from.

Deep Discharge Recovery

Special separators, advanced plate composition and a carefully balanced electrolyte system ensure that the battery has the ability to recover from excessively deep discharge.

Economical

The high watt-hour per dollar value is made possible by the materials used in a sealed lead-acid battery; they are readily available and low in cost.

Easy Handling

No special handling precautions or shipping containers, surface or air, are required due to the leak-proof construction. Please refer to the declaration of non restricted status for D.O.T. and I.A.T.A. as listed in the Literature section of our website: www.power-sonic.com.

Compact

Power-Sonic batteries utilize state of the art design, high grade materials, and a carefully controlled plate-making process to provide excellent output per cell. The high energy density results in superior power/volume and power/weight ratios.

Low Pressure Valve Regulators

All batteries feature a series of low pressure one-way relief valves. These valves safely release any excessive accumulation of gas inside the battery and then reseal.

High Discharge Rate

Low internal resistance allows discharge currents of up to ten times the rated capacity of the battery. Relatively small batteries may thus be specified in applications requiring high peak currents.

Wide Operating Temperature Range

Power-Sonic batteries may be discharged over a temperature range of -40°C to +60°C (-40°F to +140°F) and charged at temperatures ranging from -20°C to +50°C (-4°F to +122°F).

Rugged Construction

The high impact resistant battery case is made of non-conductive ABS plastic. The case materials impart great resistance to shock, vibration, chemicals and heat. Flame Retardant (FR) battery cases and lids are available where the end application dictates.

Long Service Life

PS/PSH and PSG Series: Have a design life of up to five years in standby applications. In cyclical applications up to 1,000 charge/discharge cycles can be expected depending on average depth of discharge.

PG Series: Have a design life of up to 10 years in float applications.

Please consult this Technical Manual and product specifications to become aware of the many factors that effect product life.

The information contained within is provided as a service to our customers and is for their information only. The information and recommendations set forth herein are made in good faith and are believed to be accurate at the date compiled. Power-Sonic Corporation makes no warranty expressed or implied.

Battery Construction

Terminals

Depending on the model, batteries come either with AMP Faston type terminals made of tin plated brass, post type terminals of the same composition with threaded nut and bolt hardware, or heavy duty flag terminals made of lead alloy.

A special epoxy is used as sealing material surrounding the terminals.

Relief valve

In case of excessive gas pressure build-up inside the battery, the relief valve will open and relieve the pressure. The one-way valve not only ensures that no air gets into the battery where the oxygen would react with the plates causing internal discharge, but also represents an important safety device in the event of excessive overcharge.

Vent release pressure is between 2-6 psi; the seal ring material is neoprene rubber.

Plates (electrodes)

Power-Sonic utilizes the latest technology and equipment to cast grids from a lead-calcium alloy free of antimony. The small amount of calcium and tin in the grid alloy imparts strength to the plate and guarantees durability even in extensive cycle service. Lead dioxide paste is added to the grid to form the electrically active material.

In the charged state, the negative plate paste is pure lead and that of the positive lead dioxide. Both of these are in a porous or spongy form to optimize surface area and thereby maximize capacity. The heavy duty lead calcium alloy grids provide an extra margin of performance and life in both cyclic and float applications and give unparalleled recovery from deep discharge.

Separators

Power-Sonic separators are made of non-woven glass fiber cloth with high heat and oxidation resistance. The material further offers superior electrolyte absorption and retaining ability, as well as excellent ion conductivity.

Case Sealing

Depending on the model the case sealing is ultrasonic, epoxy or heat seal.

Container

Case and lid material is ABS, high impact, resin with high resistance to chemicals and flammability. Case and cover are made of non-conductive ABS plastic to UL94-HB or UL94 V-O.

This case has molded-in dividers for each 2 volt cell.

Electrolyte

Immobilized dilute sulfuric acid: H_2SO_4 .

Leakproof Design & Operational Safety

The leak proof construction of Power-Sonic batteries has ensured that our batteries have been approved for shipment by air, both by D.O.T. and I.A.T.A. Copies of these approvals are available on our website: www.power-sonic.com.

U.L.'s component recognition program for emergency lighting and power batteries lists Power-Sonic under file number MH20845

Theory of Operation

The basic electrochemical reaction equation in a lead acid battery can be written as:



Discharge

During the discharge portion of the reaction, lead dioxide (PbO₂) is converted into lead sulfate (PbSO₄) at the positive plate. At the negative plate sponge lead (Pb) is converted to lead sulfate (PbSO₄). This causes the sulfuric acid (2H₂SO₄) in the electrolyte to be consumed.

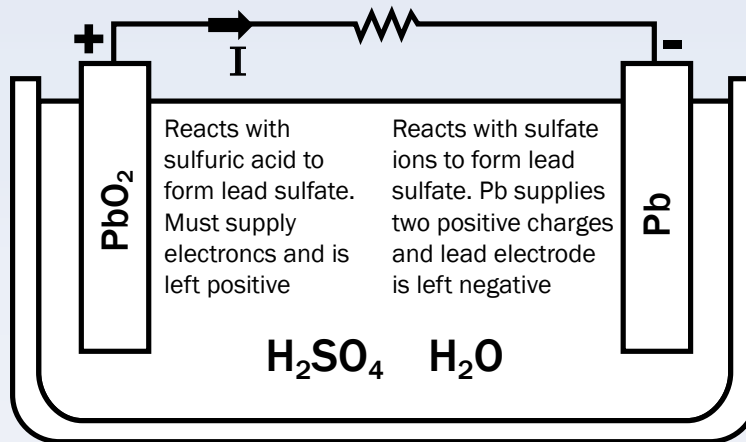

Figure 1: Chemical reaction when a battery is being discharged

Charge

During the recharge phase of the reaction, the cycle is reversed. The lead sulfate (PbSO₄) and water are electrochemically converted to lead (Pb), lead dioxide (PbO₄) and sulfuric acid (2H₂SO₄) by an external electrical charging source.

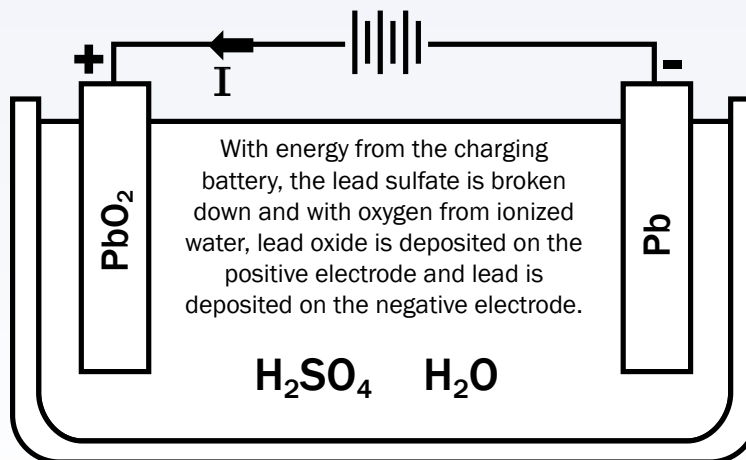

Figure 2: Chemical reaction when a battery is being charged

Theory of Operation

Oxygen Recombination

To produce a truly maintenance-free battery, it is necessary that gases generated during overcharge are recombined in a so-called "oxygen cycle". Should oxygen and hydrogen escape, a gradual drying out would occur, eventually affecting capacity and battery life.

During charge, oxygen is generated at the positive and reacts with and partially discharges the sponge lead of the negative. As charging continues the oxygen recombines with the hydrogen being generated by the negative, forming water. The water content of the electrolyte thus remains unchanged unless the charging rate is too high.

In case of rapid generation of oxygen exceeding the absorbing capacity of the negative plate, the pressure relief valve will open to release excessive gas.

Deep Discharge

Power-Sonic batteries are protected against cell shorting by the addition of a buffering agent that ensures the presence of acid ions even in a fully discharged state.

Power-Sonic defines "deep discharge" as one that allows the battery voltage under load to go below the cut-off (or "final") voltage of a full discharge. The recommended cutoff voltage varies with the discharge rate. Table 1 shows the final discharge voltages per cell.

It is important to note that deep discharging a battery at high rates for short periods is not nearly as severe as discharging a battery at low rates for long periods of time. To clarify, let's analyze two examples:

- **Battery A** – Discharged at the 1C rate to zero volts.
"C" for a 4 AH battery, for example, is 4 amps. Full discharge is reached after about 30 minutes when the battery voltage drops to 1.5V/cell. At this point, only 50% of rated capacity has been discharged (1 C amps x 0.5 hrs = 0.5C Amp. Hrs). Continuing the discharge to zero volts will bring the total amount of discharged ampere-hours to approximately 75% because the rapidly declining voltage quickly reduces current flow to a trickle. The battery will recover easily from this type of deep discharge.
- **Battery B** – Discharged at the 0.01 C rate to zero volts.
0.01C for a 4 AH battery is 40mA. Full discharge is reached after 100+ hours when the terminal voltage drops to 1.75 V/cell. At this point, the battery has already delivered 100% of its rated capacity (0.01 x 100 hrs = 1C Amp. Hrs.). Continuing the discharge to zero volts will keep the battery under load for a further period of time, squeezing out every bit of stored energy.

This type of "deep" discharge is severe and is likely to damage the battery. The sooner a severely discharged battery is recharged, the better its chances to fully recover.

Discharge Current	Final Discharge Voltage Per Cell
0.1C or below, or intermittent discharge	1.75
0.17C or current close to it	1.75
0.6C or current close to it	1.70
From 1C to 2C or current close to it	1.50
3C or current close to it and above	1.37

Table 1: Final discharge voltage per cell

Capacity

The capacity of a battery is the total amount of electrical energy available from a fully charged cell or cells. Its value depends on the discharge current, the temperature during discharge, the final (cut-off) voltage and the general history of the battery.

Table 2 shows capacities for various multiples of the 20-hour discharge current for PS, PSH and PSG models.

Rated Capacity	20 Hour Rate		10 Hour Rate		5 Hour Rate		1 Hour Rate	
	Amps	AH	Amps	AH	Amps	AH	Amps	AH
0.5 AH	0.025	0.50	0.045	0.45	0.08	0.40	0.30	0.30
0.8 AH	0.04	0.80	0.072	0.72	0.13	0.65	0.48	0.48
1.1 AH	0.055	1.10	0.10	1.00	0.19	0.95	0.68	0.68
1.4 AH	0.07	1.40	0.13	1.30	0.24	1.20	0.85	0.85
2.0 AH	0.10	2.00	0.19	1.90	0.34	1.70	1.24	1.24
2.3 AH	0.115	2.30	0.225	2.25	0.39	1.95	1.38	1.38
2.5 AH	0.125	2.50	0.22	2.20	0.40	2.00	1.50	1.50
2.8 AH	0.14	2.80	0.25	2.50	0.48	2.40	1.70	1.70
2.9 AH	0.145	2.90	0.26	2.60	0.49	2.45	1.80	1.80
3.2 AH	0.16	3.20	0.30	3.00	0.54	2.70	2.00	2.00
3.4 AH	0.17	3.40	0.33	3.30	0.58	2.90	2.20	2.20
3.5 AH	0.175	3.50	0.33	3.40	0.59	2.95	2.17	2.17
3.8 AH	0.19	3.80	0.35	3.50	0.64	3.20	2.40	2.40
4.5 AH	0.225	4.50	0.41	4.10	0.64	3.20	2.75	2.75
5.0 AH	0.25	5.00	0.43	4.30	0.80	4.00	3.00	3.00
5.4 AH	0.27	5.40	0.50	5.00	0.90	4.50	3.60	3.60
5.5 AH	0.275	5.50	0.54	5.40	0.95	4.75	3.70	3.70
6.0 AH	0.30	6.00	0.56	5.60	0.98	4.90	3.60	3.60
6.5 AH	0.325	6.50	0.61	6.10	1.10	5.50	4.03	4.03
7.0 AH	0.35	7.00	0.63	6.30	1.19	5.95	4.34	4.34
7.2 AH	0.36	7.20	0.70	7.00	1.30	6.50	4.60	4.60
8.0 AH	0.40	8.00	0.78	7.75	1.40	7.00	4.80	4.80
8.5 AH	0.425	8.50	0.81	8.10	1.50	7.50	6.50	6.50
9.0 AH	0.45	9.00	0.83	8.30	1.54	7.70	5.60	5.60
10.0 AH	0.50	10.00	0.93	9.30	1.70	8.50	6.20	6.20
10.5 AH	0.53	10.50	0.98	9.80	1.87	9.35	6.82	6.82
12.0 AH	0.60	12.00	1.15	11.50	2.10	10.50	7.30	7.30
13.0 AH	0.65	13.00	1.22	12.20	2.30	11.50	8.00	8.00
14.0 AH	0.70	14.00	1.30	13.00	2.50	12.50	8.45	8.45
18.0 AH	0.90	18.00	1.70	17.00	3.20	16.00	11.10	11.10
20.0 AH	1.00	20.00	1.85	18.50	3.40	17.00	12.40	12.40
21.0 AH	1.05	21.00	2.00	20.00	3.70	18.50	13.00	13.00
26.0 AH	1.30	26.00	2.40	24.00	4.40	22.00	16.10	16.10
28.0 AH	1.40	28.00	2.62	26.20	5.00	25.00	18.60	18.60
35.0 AH	1.75	35.00	3.30	33.00	6.20	31.00	25.00	25.00
36.0 AH	1.80	36.00	3.35	33.50	6.12	30.60	22.30	22.30
40.0 AH	2.00	40.00	3.80	38.00	6.70	33.50	24.00	24.00
55.0 AH	2.75	55.00	5.10	51.00	8.80	44.00	30.60	30.60
75.0 AH	3.75	75.00	7.20	72.00	13.60	68.00	47.00	47.00
100.0 AH	5.00	100.00	9.20	92.00	15.80	79.00	55.20	55.20
110.0 AH	5.50	110.00	10.30	103.00	17.70	88.50	61.80	61.80
140.0 AH	7.00	140.00	13.50	135.00	24.00	120.00	84.00	84.00
210.0 AH	10.50	210.00	20.00	200.00	36.00	180.00	168.00	168.00

Table 2: Capacities for various multiples of the 20-hour discharge current - PS, PSH and PSG models.

Capacity

Table 3 shows capacities for various multiples of the 20-hour discharge current for PG models.

Rated Capacity	20 Hour Rate		10 Hour Rate		5 Hour Rate		1 Hour Rate	
	Amps	AH	Amps	AH	Amps	AH	Amps	AH
28.0 AH	1.50	30.00	2.80	28.00	5.10	25.50	18.60	18.60
35.0 AH	1.80	36.00	3.50	35.00	6.50	32.50	27.00	27.00
42.0 AH	2.25	45.00	4.20	42.00	7.20	36.00	25.20	25.20
56.0 AH	3.00	60.00	5.60	56.00	9.50	47.50	33.00	33.00
65.0 AH	3.53	70.60	6.50	65.00	11.20	56.00	39.00	39.00
75.0 AH	4.00	80.00	7.50	75.00	12.90	64.50	45.00	45.00
92.0 AH	4.90	98.00	9.20	92.00	15.80	79.00	55.20	55.20
103.0 AH	5.55	111.00	10.30	103.00	17.70	88.50	61.80	61.80
124.0 AH	6.45	129.00	12.40	124.00	21.30	106.50	74.40	74.40
144.0 AH	7.70	154.00	14.40	144.00	24.08	120.40	84.00	84.00
153.0 AH	8.30	166.00	15.30	153.00	26.30	131.50	91.80	91.80
210.0 AH	11.30	226.00	21.00	210.00	36.10	180.50	126.00	126.00

Table 3: PG-Series batteries, by industry convention, are rated at their 10 hour rate.

Capacity, expressed in ampere-hours (AH), is the product of the current discharged and the length of discharge time. The rated capacity (C) of a Power-Sonic battery (PS, PSH and PSG-Series) is measured by its performance over 20 hours of constant current discharge at a temperature of 68°F (20°C) to a cut off voltage of 1.75 volts/cell.

As an example, model PS-610, with a rated capacity of 1.1 AH will deliver 55mA (1/20 of 1.1 AH, or 0.05C) for 20 hours before the voltage reaches an end voltage of 5.25 volts.

By cycling the battery a few times or float charging it for a month or two, the highest level of capacity development is achieved. Power-Sonic batteries are fully charged before leaving the factory, but full capacity is realized only after the battery has been cycled a few times or been on float charge for some time.

When a battery discharges at a constant rate, its capacity changes according to the amperage load. Capacity increases when the discharge current is less than the 20 hour rate and decreases when the current is higher.



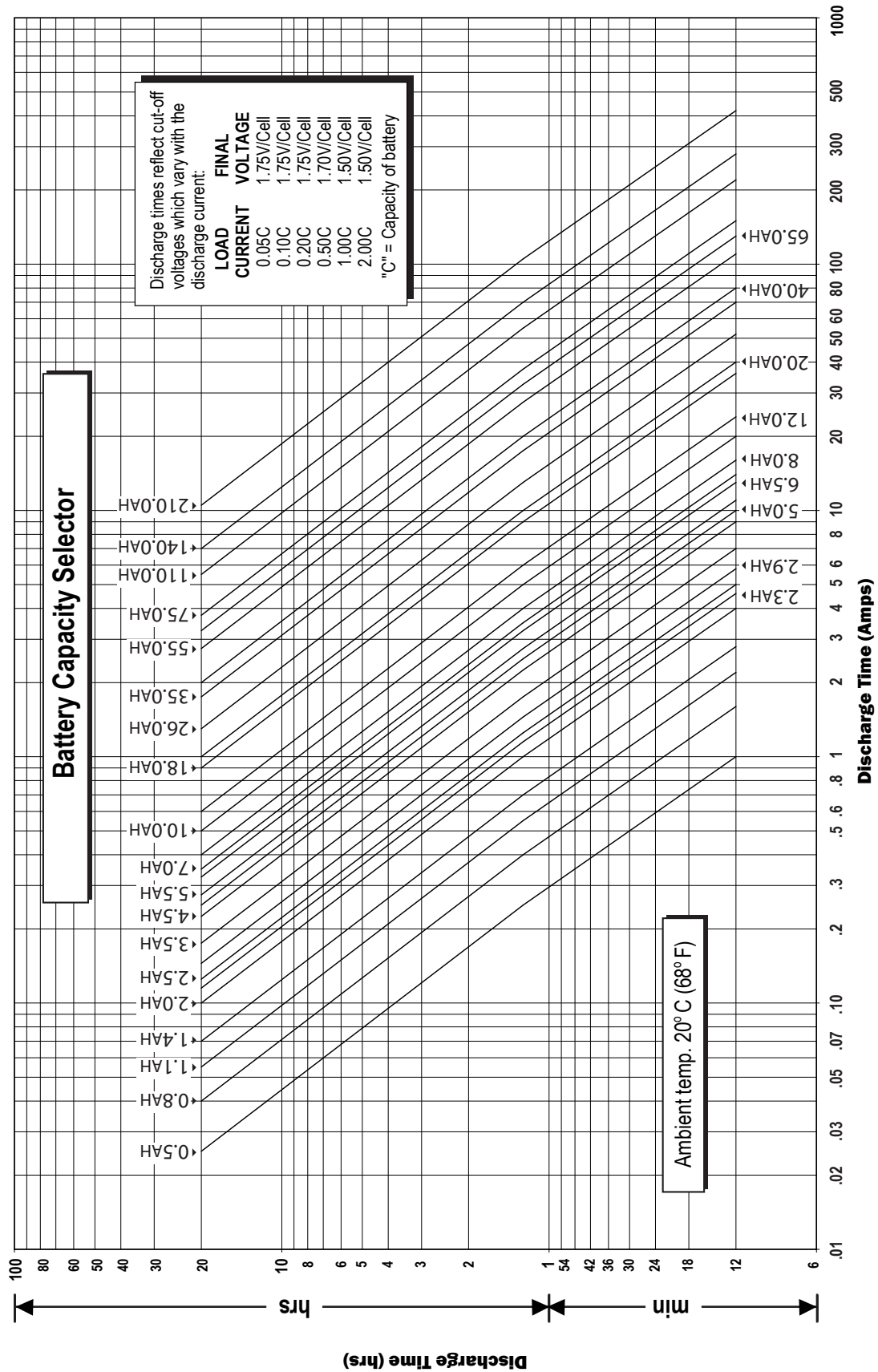

Figure 3: Capacity Lines for Power-Sonic batteries

Figure 3 shows capacity lines for major Power-Sonic battery models with different ampere-hour ratings. Amperage is on the horizontal scale and the time elapsed is on the vertical scale; the product of these values is the capacity.

Proper battery selection for a specific application can be made from this graph if the required time and current are known. For example, to determine the proper capacity of a battery providing 3 amps for 20 minutes, locate the intersection of these values on the graph. The line immediately above that point represents the battery which will meet the requirement.

Performance Data

Discharge

During discharge the voltage will decrease. The graphs in Figure 4 illustrate this for different discharge rates and ambient temperatures. "C" is the rated capacity of a battery: "C" for model PS-610 (6V – 1.1 AH) is 1.1AH. By convention the rating of nearly all sealed-lead acid batteries, is based on a 20-hour (0.05C) discharge rate. For larger batteries used for telecom and large UPS systems (our PG-Series) the convention is to use a 10-hour rate.

An important feature of Power-Sonic batteries is shown in the discharge curves; namely, the voltage tends to remain high and almost constant for a relatively long period before declining to an end voltage.

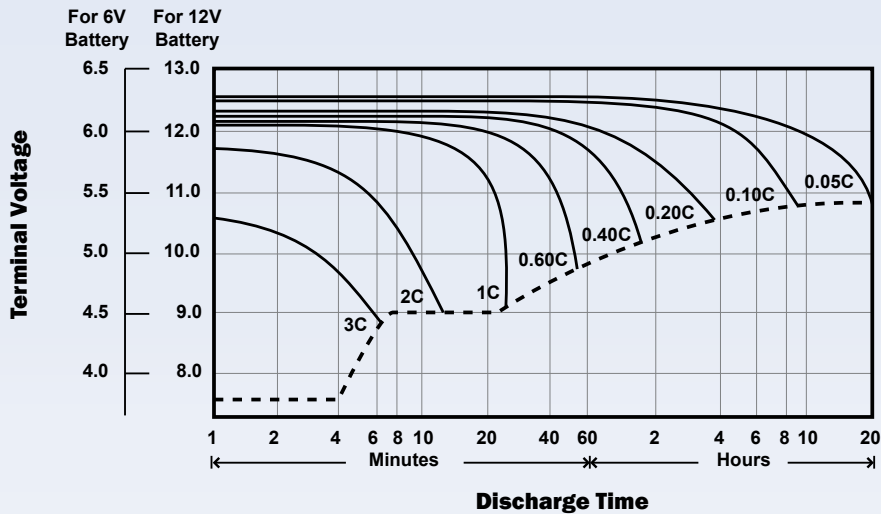

Figure 4: Discharge Characteristic Curves at 20°C (68°F)

Open-Circuit Voltage

Open circuit voltage varies according to ambient temperature and the remaining capacity of the battery. Generally, open circuit voltage is determined by the specific gravity of the electrolyte. Discharging a battery lowers the specific gravity. The open circuit voltage of a Power-Sonic battery is 2.16 V/cell when fully charged and 1.94 V/cell when completely discharged.

As seen in Figure 4, under load, the battery can deliver useful energy at less than 1.94 V/cell, but after the load is removed the open circuit voltage will "bounce back" to voltages shown in Figure 5, dependent upon residual capacity.

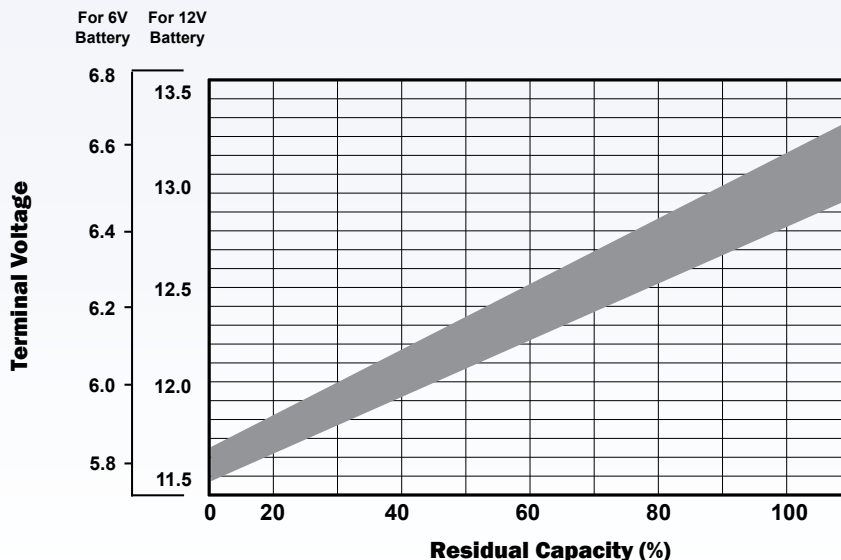

Figure 5: Open-Circuit Voltage Characteristics

Performance Data

Temperature

Actual capacity is a function of ambient temperature and rate of discharge. At 68°F (20°C) rated capacity is 100%. The capacity increases slowly above this temperature and decreases as the temperature falls. Even at -40°F (-40°C), however, the Power-Sonic battery will still function at better than 30% of its rated capacity when discharged at the 20-hour rate (0.05C). At any ambient temperature, the higher the rate of discharge, the lower the available capacity. This relationship is shown in Figure 6.

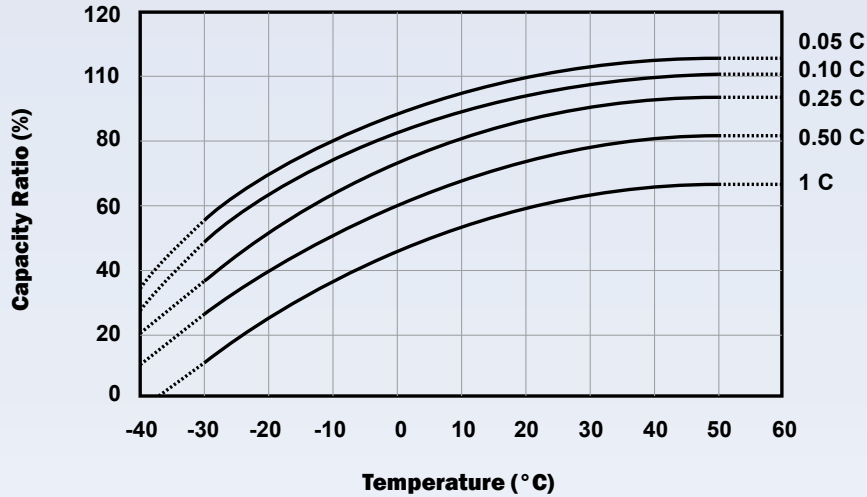

Figure 6: Effect of Temperature on Capacity

Power-Sonic batteries may be discharged at temperatures ranging from -40°F to 140°F (-40°C to 60°C) and charged at temperatures from -4°F to 122°F (-20°C to 50°C).

While raising ambient temperature increases capacity, it also decreases useful service life. It is estimated that battery life is halved for each 18°F (10°C) above normal room temperature.

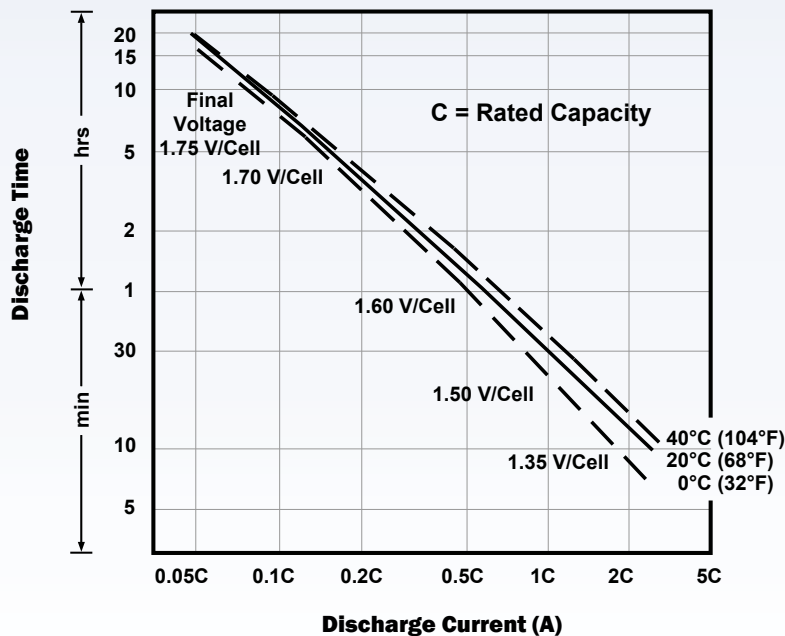

Figure 7: Relationship between current and discharge time for different ambient temperatures

Performance Data

Shelf Life & Storage

Low internal resistance and special alloys in the electrodes assure a low self discharge rate and, consequently, a long shelf life. If kept at 68°F (20°C), about 60-70% of the nominal capacity remains after one year of storage. Due to the self-discharge characteristics of this type of battery, it is imperative that they be charged within 6 months of storage, otherwise permanent loss of capacity might occur as a result of sulfation.

The rate of self discharge varies with the ambient temperature. At room temperature (68°F/20°C) it is about 3% per month. At low temperatures it is nearly negligible; at higher ambient temperatures self discharge increases.

To obtain maximum battery life and performance, batteries should be recharged as soon as possible after each use and not stored in a discharged state. If possible batteries should be stored at 68°F (20°C) or lower, and recharged every six months when not in use.

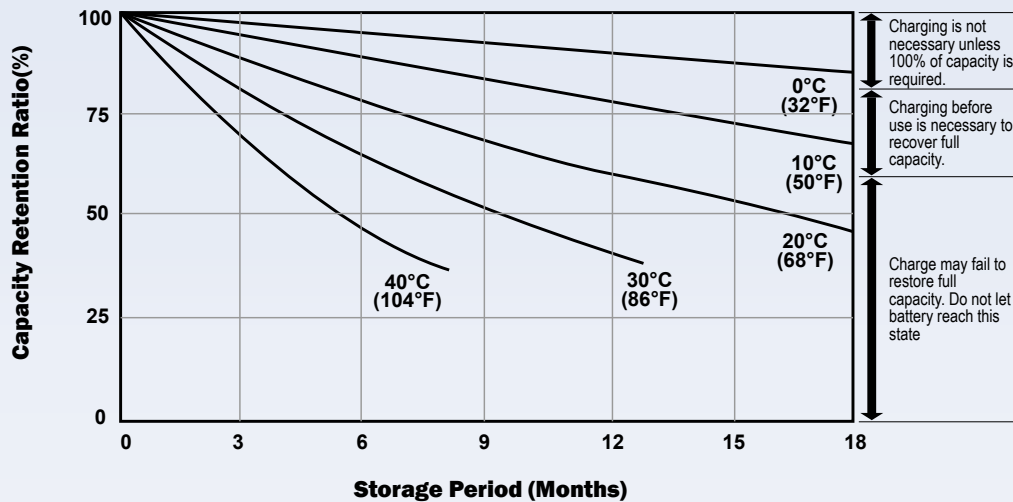

Figure 8: Self Discharge Characteristics

Battery Life

Cyclic Use: The number of charge/discharge cycles depends on the capacity taken from the battery (a function of discharge rate and depth of discharge), operating temperature and the charging method.

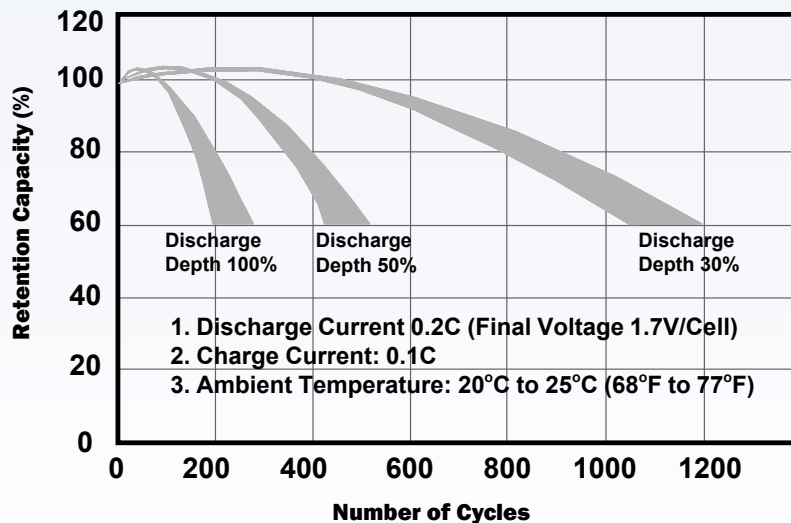

Figure 9: Relationship between depth of discharge and number of cycles as well as increases of capacity during the early cycles.

Performance Data

Battery Life (continued)

Standby Use: The float service life, or life expectancy under continuous charge, depends on the frequency and depth of discharge, the charge voltage, and the ambient temperature. At a float voltage of 2.25V to 2.30V/cell and an ambient temperature of 60°F to 77°F (20 °C to 25 °C) Power-Sonic batteries should last four to five years before the capacity drops to 60% of its original rating.

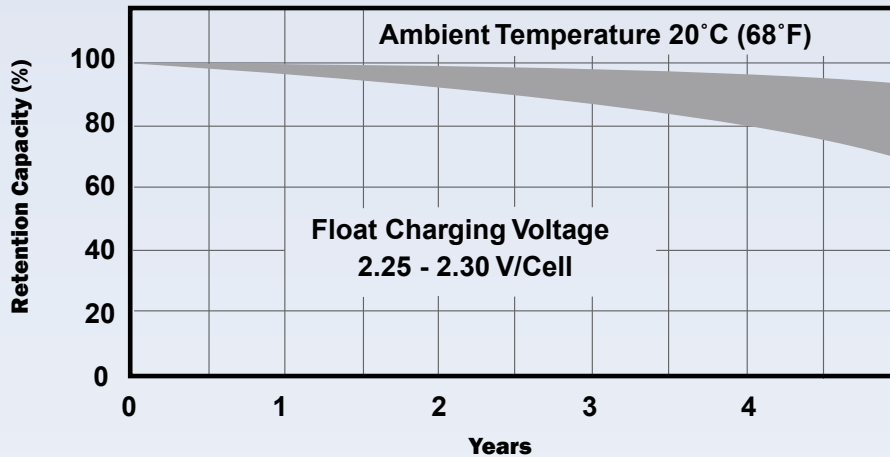

Figure 10: Indicates how capacity changes over time.

The graph in Figure 11 shows life characteristics in float (standby) service for ambient temperatures ranging from 15 °C to 55 °C (60°F to 130°F). If prevailing ambient temperatures are well above 20-25 °C (68-77°F) the life expectancy of this type of battery in float service depends greatly on temperature compensated charging. The typical temperature coefficient is 2mV/cell/20°C and under.

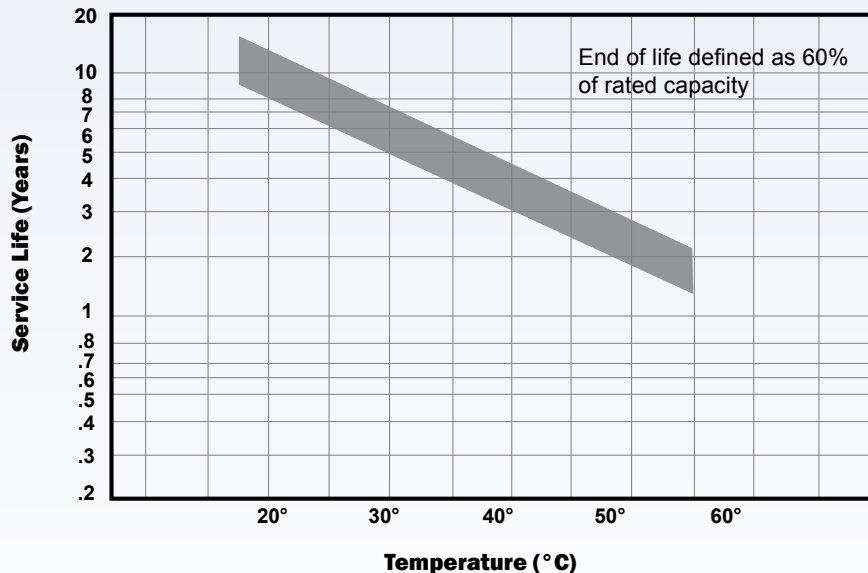

Figure 11: Service life at various ambient temperatures

Performance Data

Over Discharge

To optimize battery life, it is recommended that the battery be disconnected from the load (either electronically or manually) when the end voltage - a function of the discharge rate - is reached. It is the voltage point at which 100% of the usable capacity of the battery has been consumed or continuation of the discharge is useless because of the voltage dropping below useful levels. The final discharge voltages per cell are shown in Table 1.

Discharging a sealed lead-acid battery below this voltage or leaving a battery connected to a load will impair the battery's ability to accept a charge. To prevent potential over discharge problems, voltage cut off circuits as shown in Figure 12 may be used.

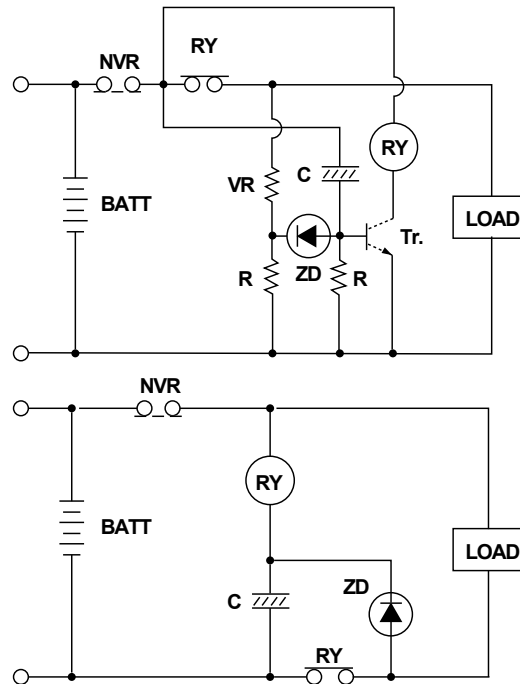

Figure 12: Circuits of Over-Discharge Preventative Device

Charging

Dependable performance and long service life depend upon correct charging. Faulty procedures or inadequate charging equipment result in decreased battery life and/or unsatisfactory performance. The selection of suitable charging circuits and methods is as important as choosing the right battery for the application.

Power-Sonic batteries may be charged by using any of the conventional charging techniques:

- Constant Voltage
- Constant Current
- Taper-Current
- Two Step Constant Voltage

To obtain maximum service life and capacity, along with acceptable recharge time and economy, constant voltage-current limited charging is recommended.

To charge a Power-Sonic SLA battery, a DC voltage between 2.30 volts per cell (float) and 2.45 volts per cell (fast) is applied to the terminals of the battery. Depending on the state of charge, the cell may temporarily be lower after discharge than the applied voltage. After some time, however, it should level off.

During charge, the lead sulfate of the positive plate becomes lead dioxide. As the battery reaches full charge, the positive plate begins generating dioxide causing a sudden rise in voltage due to decreasing internal resistance. A constant voltage charge, therefore, allows detection of this voltage increase and thus control of the current charge amount.

Additional information regarding charging methods can be found on pages 13 through 19.

Charging

Charging Characteristics

During constant voltage or taper charging, the battery's current acceptance decreases as voltage and state of charge increase. The battery is fully charged once the current stabilizes at a low level for a few hours. Please note that there are two criteria for determining when a battery is fully charged: (1) the final current level and (2) the peak charging voltage while this current flows.

Charging Methods

Selecting the appropriate charging method depends on the intended use (cyclic or float service), economic considerations, recharge time, anticipated frequency and depth of discharge, and expected service life. The key goal of any charging method is to control the charge current at the end of the charge.

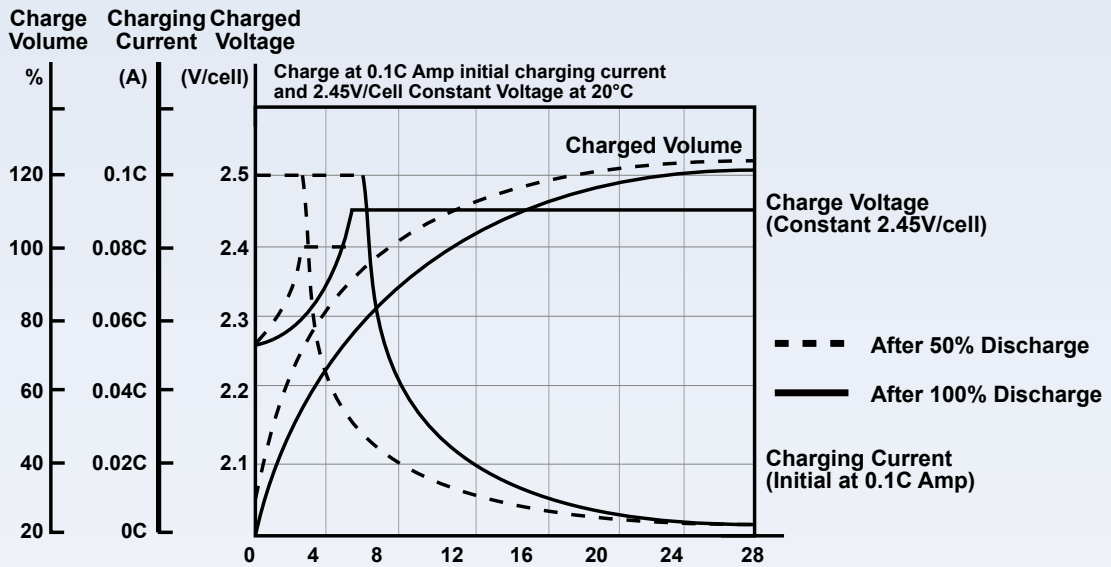

Figure 13: Typical charge characteristics for cycle service where charging is non-continuous and peak voltage can be higher.

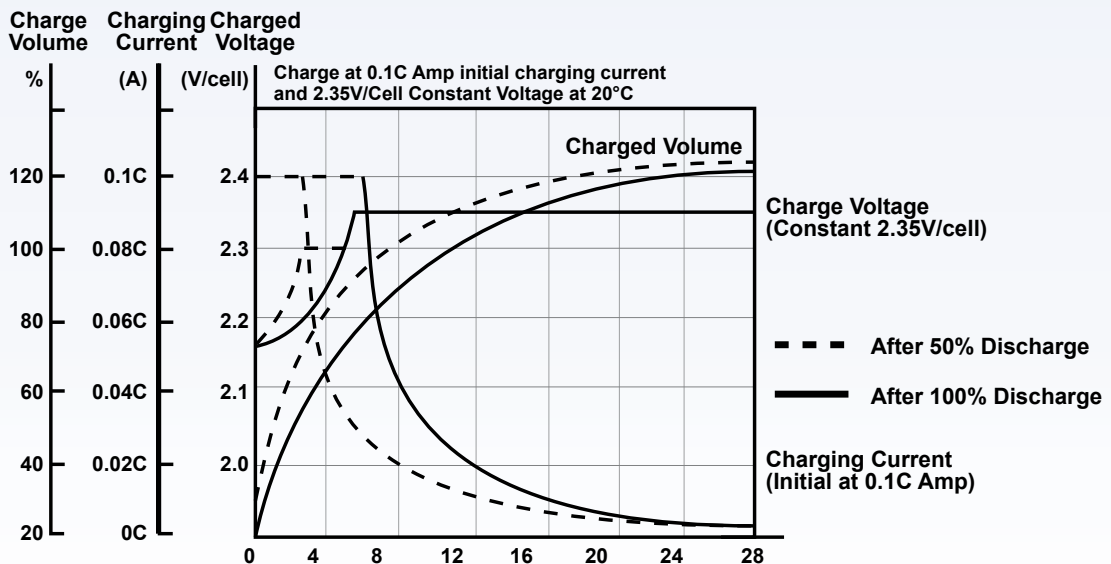

Figure 14: Typical characteristics for standby service type charge. Here, charging is continuous and the peak charge voltage must be lower.

Charging

Constant Voltage Charging

Constant voltage charging is the best method to charge Power-Sonic batteries. Depending on the application, batteries may be charged either on a continuous or non-continuous basis. In applications where standby power is required to operate when the AC power has been interrupted, continuous float charging is recommended. Non-continuous cyclic charging is used primarily with portable equipment where charging on an intermittent basis is appropriate.

The constant voltage charge method applies a constant voltage to the battery and limits the initial charge current. It is necessary to set the charge voltage according to specified charge and temperature characteristics. Inaccurate voltage settings cause over- or under-charge. This charging method can be used for both cyclic and standby applications.

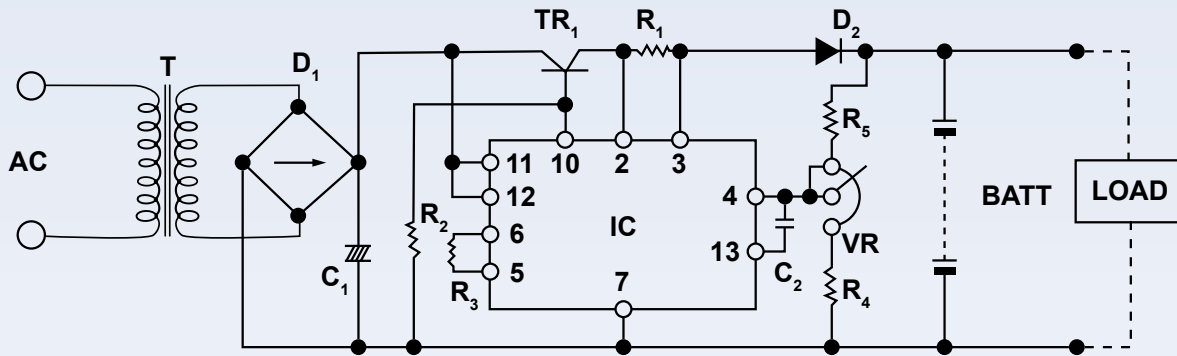

Figure 15: Constant voltage charging circuit

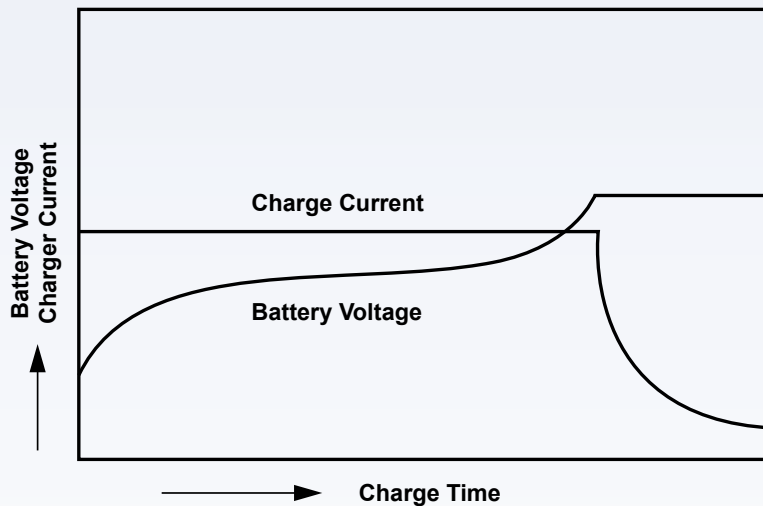

Figure 16: Constant voltage charging characteristics

Charging

Constant Current Charging

Constant current charging is suited for applications where discharged ampere-hours of the preceding discharge cycle are known. Charge time and charge quantity can easily be calculated, however an expensive circuit is necessary to obtain a highly accurate constant current. Monitoring of charge voltage or limiting of charge time is necessary to avoid excessive overcharge.

While this charging method is very effective for recovering the capacity of a battery that has been stored for an extended period of time, or for occasional overcharging to equalize cell capacities, it lacks specific properties required in today's electronic environment.

Taper-Current Charging

This method is not recommended as it is somewhat abusive of sealed lead acid batteries and can shorten service life. However, because of the simplicity of the circuit and low cost, taper-current charging is extensively used to charge multiple numbers and/or for cyclic charging.

When using a taper-current charger the charger time should be limited or a charging cut-off circuit be incorporated to prevent overcharge. Please contact our technical department if you need assistance with this.

In a taper-current charging circuit, the current decreases in proportion to the voltage rise. When designing a taper charger always consider power voltage fluctuations. In this event the internal resistance drop will convert to heat. Heat generated by the circuit should be measured and if required a heat sink should be incorporated in the design.

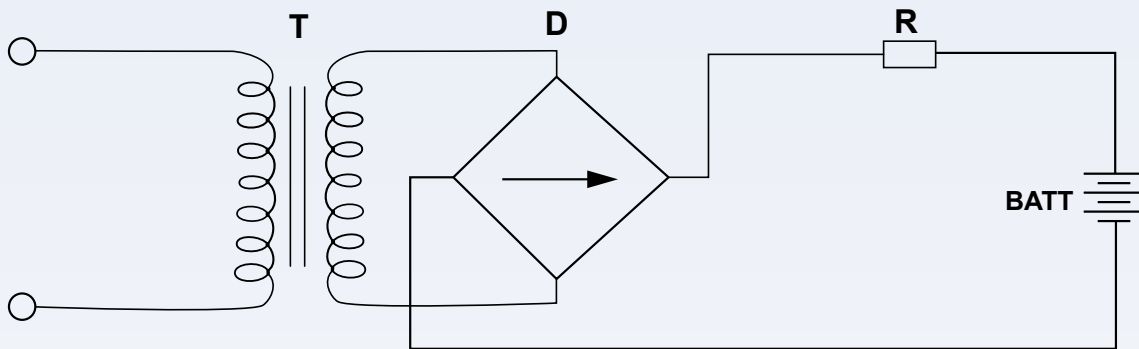

Figure 17: Taper-current charging circuit

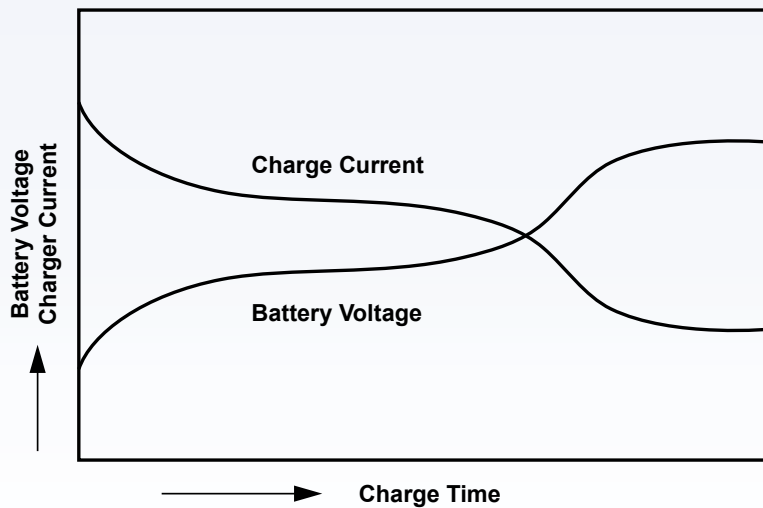

Figure 18: Taper-current charging characteristics for this type of basically unregulated charger.

Charging

Overcharging

As a result of too high a charge voltage excessive current will flow into the battery, after reaching full charge, causing decomposition of water in the electrolyte and premature aging.

At high rates of overcharge a battery will progressively heat up. As it gets hotter, it will accept more current, heating up even further. This is called thermal runaway and it can destroy a battery in as little as a few hours.

Undercharging

If too low a charge voltage is applied, the current flow will essentially stop before the battery is fully charged. This allows some of the lead sulfate to remain on the electrodes, which will eventually reduce capacity.

Batteries which are stored in a discharged state, or left on the shelf for too long, may initially appear to be “open circuited” or will accept far less current than normal. This is caused by a phenomenon called “sulfation”. When this occurs, leave the charger connected to the battery. Usually, the battery will start to accept increasing amounts of current until a normal current level is reached. If there is no response, even to charge voltages above recommended levels, the battery may have been in a discharged state for too long to recover.

Caution! Never charge or discharge a battery in a hermetically sealed enclosure. Batteries generate a mixture of gases internally. Given the right set of circumstances, such as extreme overcharging or shorting of the battery, these gases might vent into the enclosure and create the potential for an explosion when ignited by a spark.

If in any doubt, or if concepts of proper use and care are unclear, please ensure that you contact Power-Sonic's technical department.

Charging for Cycle Operation

Cyclic applications generally require that recharging be done in a relatively short time. The initial charge current, however, must not exceed $0.30 \times C$ amps. Just as battery voltage drops during discharge, it slowly rises during charge. Full charge is determined by voltage and inflowing current. When, at a charge voltage of 2.45 ± 0.05 volts/cell, the current accepted by the battery drops to less than $0.01 \times C$ amps (1% of rated capacity), the battery is fully charged and the charger should be disconnected or switched to a float voltage of 2.25 to 2.30 volts/cell. The voltage should not be allowed to rise above 2.45 ± 0.05 volts/cell.

Charging for Standby Operation

Standby applications generally do not require that the battery be charged as fast or as frequently as in cycle operation. However, the battery must be kept constantly charged to replace the energy that is expended due to internal loss and deterioration of the battery itself. Although these losses are very low in Power-Sonic batteries, they must be replaced at the rate the battery self discharges; at the same time the battery must not be given more than these losses or it will be overcharged. To accomplish this, a constant voltage method of charging called “float charging” is used.

The recommended constant float voltage is 2.25 - 2.30 volts per cell. Maintaining this float voltage will allow the battery to define its own current level and remain fully charged without having to disconnect the charger from the battery. The trickle current for a fully charged battery floating at the recommended charge voltage will typically hover around the $0.001C$ rate (10mA for a 10AH battery, for example.)

The float charger is basically a constant voltage power supply. As in cycle chargers, care must be exercised not to exceed the initial charge current of $0.30 \times C$ amperes.

Charging

Two-Step Constant Voltage Charging

This method uses two constant voltage devices. In the initial charge phase the high voltage setting is used. When charging is nearly complete and the charge voltage has risen to a specified value (with the charge current decreased), the charger switches the voltage to the lower setting. This method allows rapid charging in cycle or float service without the possibility of overcharging, even after extended charging periods.

Temperature compensated
at 2 mV/cell/C

Select R_s to give correct float voltage
at desired min. current: $0.6/R_3 = I_{max}$.

Select R_{isw} to turn on Q2 at
desired current $I_{sw} = R_{isw}/0.6$

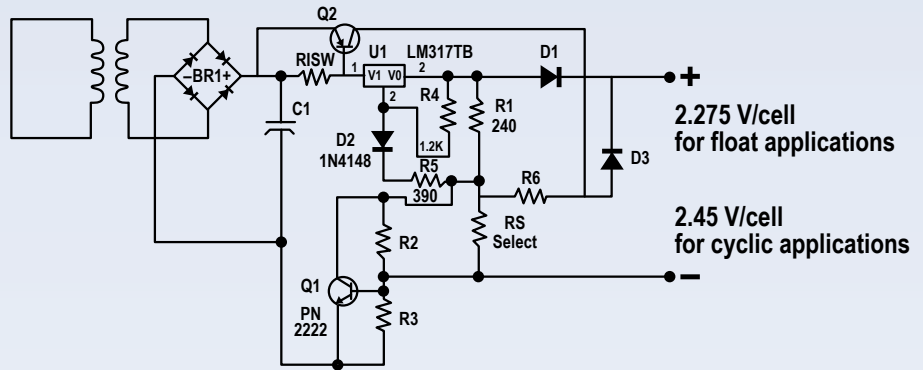

Figure 19: Dual stage current limited battery charger.

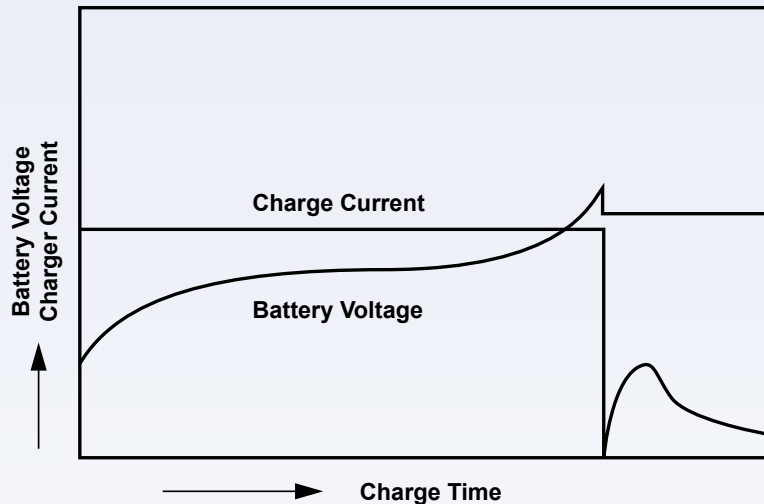

Figure 20: Two-step constant voltage charging characteristics.

Charging in Series

Lead-acid batteries are strings of 2 volt cells connected in series, commonly 2, 3, 4 or 6 cells per battery. Strings of Power-Sonic batteries, up to 48 volts and higher, may be charged in series safely and efficiently. However, as the number of batteries in series increases, so does the possibility of slight differences in capacity. These differences can result from age, storage history, temperature variations or abuse.

When a single constant voltage charger is connected across an entire high voltage string, the same current flows through all cells in the string. Depending on the characteristics of the individual batteries, some may overcharge while others remain in a slightly undercharged condition.

To minimize the effects of individual battery differences, use batteries of the same age, amp hour, and history and, if possible, charge in strings of no greater than 24 or 48 volts.

Charging

Charging in Parallel

Power-Sonic batteries may be used in parallel with one or more batteries of equal voltage.

When connected in parallel, the current from a charger will tend to divide almost equally between the batteries. No special matching of batteries is required. If the batteries of unequal capacity are connected in parallel, the current will tend to divide between the batteries in the ratio of capacities (actually, internal resistances).

When charging batteries in parallel, where different ratios of charge are to be expected, it is best to make provisions to assure that the currents will not vary too much between batteries. Holding a small resistance in series with each battery is all that is needed.

Temperature Compensation

Power-Sonic batteries perform well both at low and high temperatures. At low temperatures, however, charge efficiency is reduced; at temperatures above 45 °C, charge efficiency increases so rapidly that there is a danger of thermal runaway if temperature compensation is not precise.

The effect of temperature on charge voltage is less critical in float applications than in cyclic use, where relatively high charge currents are applied for the purpose of short recharge times.

Temperature effects should definitely be considered when designing or selecting a charging system. Temperature compensation is desirable in the charging circuit, especially when operating outside the range of 41 °F to 95 °F (5 °C to 35 °C). The temperature coefficient is -2mV/cell/°C below 20 °C in float use and -6mV/cell/ °C below 20 °C in cyclic use. For higher temperatures the charge voltage should be correspondingly decreased.

Ambient Charge Voltage Per Cell

Temperature	Cyclic Use (V)	Float Use (V)
-40 °F (-40 °C)	2.85 – 2.95	2.38 – 2.43
-4 °F (-20 °C)	2.67 – 2.77	2.34 – 2.39
14 °F (-10 °C)	2.61 – 2.71	2.32 – 2.37
32 °F (0 °C)	2.55 – 2.65	2.30 – 2.35
50 °F (10 °C)	2.49 – 2.59	2.28 – 2.33
68 °F (20 °C)	2.43 – 2.53	2.26 – 2.31
77 °F (25 °C)	2.40 – 2.50	2.25 – 2.30
86 °F (30 °C)	2.37 – 2.47	2.24 – 2.29
104 °F (40 °C)	2.31 – 2.41	2.22 – 2.27
122 °F (50 °C)	2.25 – 2.35	2.20 – 2.25

Table 4: Recommended charge voltages for different temperatures.

Top Charging

All battery lose capacity through self-discharge, it is recommended that a “top up charge” be applied to any battery that has been stored for a long period of time, prior to putting the battery into service.

To successfully top charge a battery stored for more than 12 months, the open circuit voltage must be higher than 2.0 volts per cell, in this case, always confirm open circuit voltage prior to attempting top up charging.

Charging

Charging Efficiency

The charging efficiency (η) of a battery is expressed by the following formula:

$$\eta = \frac{\text{AH Discharged After Fully Charged}}{\text{AH Delivered to Battery During Charge}}$$

The charging efficiency varies depending upon the state of charge of the battery, temperatures, and charging rates. Figure 21 illustrates the concept of the state of charge and charging efficiency. As shown in Figure 22, Power-Sonic batteries exhibit very high charging efficiency, even when charged at low charging rates.

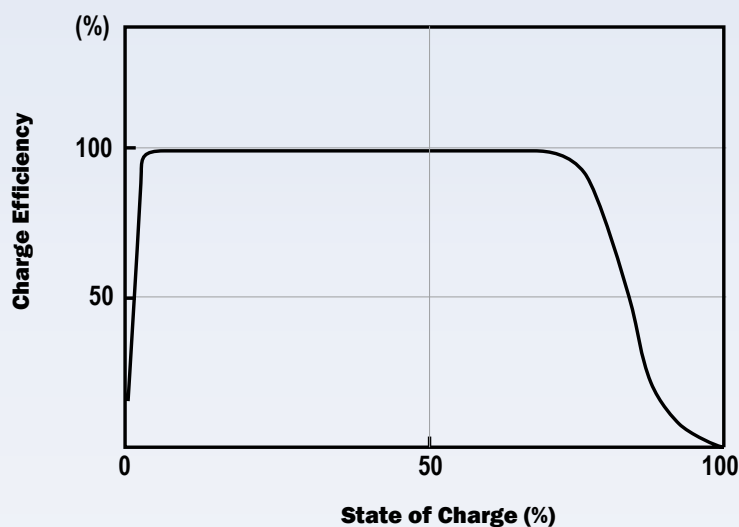

Figure 21: Charge efficiency vs. state of charge.

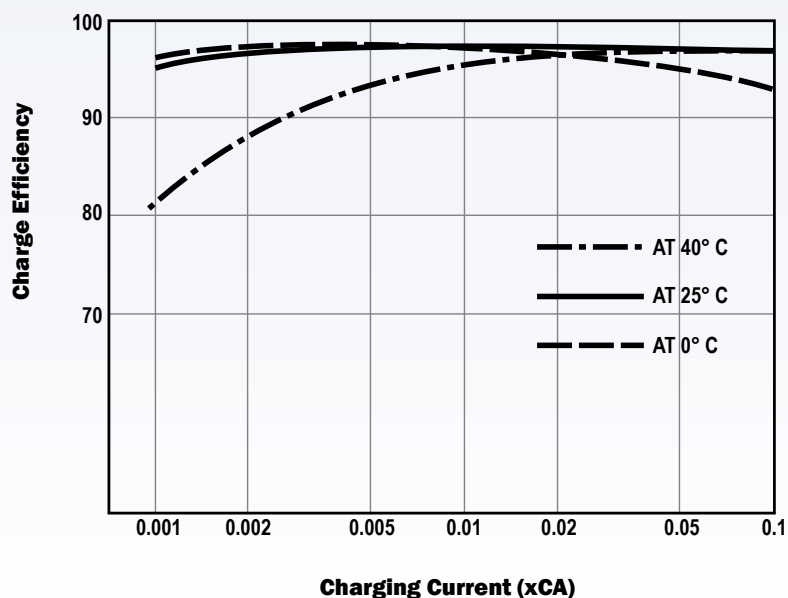

Figure 22: Charge efficiency vs. charging current.

Important Do's and Don'ts

Power-Sonic rechargeable sealed lead-acid batteries are designed to provide years of dependable service. Adherence to the following guidelines will ensure that battery life is maximized and operation is trouble-free.

Material Safety Data Sheets (MSDS)

- It is important that you familiarize yourself with these prior to handling, installing and disposing of all batteries. If there are any questions raised from these please contact Power-Sonic's technical department.

Handling

- Always wear insulated gloves when handling batteries; especially when connecting series and parallel groups of batteries.
- Follow all precautions as described in our Materials Safety Data Sheets (MSDS). This information is subject to change depending upon government legislation. Visit our website: www.power-sonic.com for up-to-date copies of these.
- If equipment is to be stored for a long period of time the batteries should be disconnected to avoid undue drain on the batteries and any potential for damage to the equipment.

Installation

- Fasten batteries tightly and make provisions for shock absorption if exposure to shock or vibration is likely.
- When installing the battery within a piece of equipment, fix it securely at the lowest practicable point.
- The battery should not be attached to any piece of equipment during "burn-in" testing.
- Do not apply undue force to the terminals or bend them. Avoid applying heat to the terminals through processes such as soldering.
- If soldering to the battery terminals is unavoidable it must be accomplished within 3 seconds, using a soldering iron no greater than 100 watts.
- Do not place batteries in close proximity to objects which can produce sparks or flames, and do not charge batteries in an inverted position.
- Avoid exposing batteries to heat! Care should be taken to place batteries away from heat-emitting components. If close proximity is unavoidable, provide ventilation. Service life is shortened considerably' at ambient temperatures above 30 °C.
- To prevent problems arising from heat exchange between batteries connected in series or parallel, it is advisable to provide air space of at least 0.4" (10mm) between batteries.
- Do not mix batteries with different capacities, different ages or of different makes. The difference in characteristics will cause damage to the batteries and possibly to the attached equipment.
- Battery cases and lids made of ABS plastic can sustain damage if exposed to organic solvents or adhesives.
- For best results and generally acceptable performance and longevity, keep operating temperature range between -40 °F (-40 °C) and 140 °F (60 °C).
- It is good practice to ensure that the connections are re-torqued and the batteries are cleaned periodically.
- Do not attempt to disassemble batteries. Contact with sulfuric acid may cause harm. Should it occur, wash skin or clothes with liberal amounts of water. Do not throw batteries into a fire; batteries so disposed may rupture or explode. Disassembled batteries are hazardous waste and must be treated accordingly.

Important Do's and Don'ts

Charging

- Batteries should not be stored in a discharged state or at elevated temperatures. If a battery has been discharged for some time, or the load was left on indefinitely, it may not readily take a charge. To overcome this, leave the charger connected and the battery should eventually begin to accept charge.
- Continuous over-or undercharging is the single worst enemy of a lead-acid battery. Caution should be exercised to ensure that the charger is disconnected after cycle charging, or that the float voltage is set correctly.
- Although Power-Sonic batteries have a low self-discharge rate which permits storage of a fully charged battery for up to a year, it is important that a battery be charged within 6 months after receipt to account for storage from the date of manufacture to the date of purchase. Otherwise, permanent loss of capacity might occur as a result of sulfation. To prolong shelf life without charging, store batteries at 50 °F (10 °C) or less.
- Although it is possible to charge Power-Sonic batteries rapidly, i.e. in 6-7 hrs. it is not normally recommended. Unlimited current charging can cause increased off-gassing and premature drying. It can also produce internal heating and hot spots resulting in shortened service life. Too high a charge current will cause a battery to get progressively hotter. This can lead to “thermal runaway” and can destroy a battery in as little as a few hours.
- Caution: Never charge or discharge a battery in an airtight enclosure. Batteries generate a mixture of gases internally. Given the right set of circumstances, such as extreme overcharging or shorting of the battery, these gases might vent into the enclosure and create the potential for an explosion when ignited by a spark. Generally, ventilation inherent in most enclosures is sufficient to avoid problems.
- When charging batteries in series (positive terminal of one battery is connected to the negative terminal of another) the interconnecting cables must all be of equal length and resistance to insure equalization of the load. All batteries in the string will receive the same amount of charge current, though individual battery voltages may vary.
- When charging batteries in parallel (positive terminals are connected to the positive terminal and negative terminals to the negative), all batteries in the string will receive the same charge voltage, but the charge current each battery receives will vary until equalization is reached.
- High voltage strings of batteries in series should be limited to twenty 6 volt or ten 12 volt batteries when a single constant voltage charger is connected across the entire string. Differences in capacity can cause some batteries to overcharge while others remain undercharged thus causing premature aging of batteries. It is, therefore, not advisable to mix batteries of different capacities, make, or age in a series string.
- To minimize the effects of cell or battery differences, charge the string in 24 volt battery groups through a constant current source with zener diode regulation across individual batteries or battery groups.
- Recharge time depends on the depth of the preceding discharge and the output current of the charger. To determine the approximate recharge time of a fully discharged battery, divide the battery's capacity (amp. hrs) by the rated output of the charger (amps) and multiply the resulting number of hours by a factor of 1.75 to compensate for the declining output current during charge. If the amount of amp. hrs. discharged from the battery is known, use it instead of the battery's capacity to make the calculation.



Glossary

Active Material

The active electro-chemical materials used in the manufacture of positive and negative electrodes.

Ambient Temperature

The prevailing surface temperature to which a battery is exposed.

Ampere

Unit of measurement for electric current.

Ampere-Hour

The product of current (amperes) multiplied by time (hours). Used to indicate the capacity of a battery. Also Amp. Hr. or A.H.

Battery

Two or more cells connected together, most typically in series.

C

Used to signify a charge or discharge rate equal to the capacity of a battery divided by one hour. Thus C for a 1600 mAh battery would be 1.6 A. C/5 for the same battery would be 320 mA and C/10 would be 160 mA.

Capacity

The electrical energy available from a cell or battery expressed in ampere-hours.

- **Available capacity:** ampere-hours that can be discharged from a battery based on its state of charge, rate of discharge, ambient temperature, and specified cut-off voltage.
- **Rated capacity ("C"):** the discharge capacity the manufacturer states may be obtained at a given discharge rate and temperature.
- **Capacity fade:** the loss of capacity due to inadequate recharging.

Cell

The basic building block of a battery. The nominal voltage of a lead-acid cell is 2 volts.

- **Cell reversal:** the act of driving a cell into reverse polarity by excessive discharge.
- **Primary cell:** cell or battery that can be discharged only once.
- **Secondary cell:** the process is reversible so that charging and discharging may be repeated over and over.

Charge

The conversion of electrical energy to chemical energy; the process which restores electrical energy to a cell or battery.

- **Charge retention:** a battery's ability to hold a charge. It diminishes during storage.
- **Charge acceptance:** quantifies the amount of electric charge that accumulates in a battery.
- **Float charge:** maintains the capacity of a cell or battery by applying a constant voltage.

Charge (Continued)

- **Trickle charge:** maintains the capacity of a cell or battery by applying a small constant current.
- **Charge equalization:** brings all of the cells in a battery or string to the same state of charge.

Closed Circuit Voltage Test

A test method in which the battery is briefly discharged at a constant current while the voltage is measured.

Cutoff Voltage

The final voltage of a cell or battery at the end of charge or discharge.

Cycle

A single charge and discharge of a cell or battery.

Deep Cycle

A cycle in which the discharge continues until the battery reaches its cut-off voltage, usually 80% of discharge.

Direct Current (DC)

The type of electrical current that a battery can supply. One terminal is always positive and the other always negative.

Discharge

The process of drawing current from a battery.

- **Deep Discharge:** the discharge of a cell or battery to between 80% and 100% of rated capacity.
- **Depth of Discharge:** the amount of capacity - typically expressed as a percentage - removed during discharge.
- **Self Discharge:** the loss of capacity while stored or while the battery is not in use.
- **Self Discharge Rate:** the percent of capacity lost on open circuit over a specified period of time.

Drain

The withdrawal of current from a battery.

Electrode

Positive or negative plate containing materials capable of reacting with electrolyte to produce or accept current.

Electrolyte

Conducts ions in a cell. Lead acid batteries use a sulfuric acid solution.

End of Charge Voltage

The voltage reached by the cell or battery at the end of charge, while the charger is still attached.

Energy Density

Ratio of battery energy to volume or weight expressed in watt-hours per cubic inch or pound.

Glossary

Gas Recombination

The process by which oxygen gas generated from the positive plate during the final stage of charge is absorbed into the negative plate, preventing loss of water.

High Rate Discharge

A very rapid discharge of the battery. Normally in multiples of C (the rating of the battery expressed in amperes).

Impedance

The resistive value of a battery to an AC current expressed in ohms (Ω). Generally measured at 1000 Hz at full charge.

Internal Resistance

The resistance inside a battery which creates a voltage drop in proportion to the current draw.

Negative Terminal

The terminal of a battery from which electrons flow in the external circuit when a battery discharges. See Positive Terminal

Nominal Voltage / Nominal Capacity

The nominal value of rated voltage / the nominal value of rated capacity. The nominal voltage of a lead-acid battery is 2 volts per cell.

Open Circuit Voltage

The voltage of a battery or cell when measured in a no load condition.

Overcharge

The continuous charging of a cell after it achieves 100% of capacity. Battery life is reduced by prolonged overcharging.

Parallel Connection

Connecting a group of batteries or cells by linking all terminals of the same polarity. This increases the capacity of the battery group.

Polarity

The charges residing at the terminals of the battery.

Positive Terminal

The terminal of a battery toward which electrons flow through the external circuit when the cell discharges. See Negative Terminal.

Rated Capacity

The capacity of the cell expressed in amperes. Commonly, a constant current for a designated number of hours to a specified depth of discharge at room temperature.

Recombination

The state in which the gasses normally formed within the battery cell during its operation are recombined to form water.

Series Connection

The connection of a group of cells or batteries by linking terminals of opposite polarity. This increases the voltage of the battery group.

Self Discharge

The loss of capacity of a battery while in stored or unused condition without external drain.

Separator

Material isolating positive from negative plates. In sealed lead acid batteries it normally is absorbent glass fiber to hold the electrolyte in suspension.

SLA Battery

Sealed lead-acid battery, generally having the following characteristics: Maintenance-free, leak-proof, position-insensitive. Batteries of this type have a safety vent to release gas in case of excessive internal pressure build-up. Hence also the term: Valve regulated battery.

“Gel Cells” are SLA batteries whose dilute sulfuric acid electrolyte is immobilized by way of additives which turn the electrolyte into a gel.

Service Life

The expected life of a battery expressed in the number of total cycles or years of standby service to a designated remaining percentage of original capacity.

Shelf Life

The maximum period of time a battery can be stored without supplementary charging.

Standby Service

An application in which the battery is maintained in a fully charged condition by trickle or float charging.

State of Charge

The available capacity of a battery at a given time expressed as a percentage of rated capacity.

Sulfation

The formation or deposit of lead sulfate on the surface and in the pores of the active material of the batteries' lead plates. If the sulfation becomes excessive and forms large crystals on the plates the battery will not operate efficiently and may not work at all.

Thermal Runaway

A condition in which a cell or battery on constant potential charge can destroy itself through internal heat generation.

Valve Regulated Lead Acid Battery (VRLA)

See “SLA Battery” listed above.



Quality is always #1

We employ IQC, PQC and ISO 9001 Quality Management Systems to test materials, monitor manufacturing processes and evaluate finished products prior to shipment. All our batteries are 100% tested with advanced computer equipment prior to being released for sale.

Power-Sonic management and staff are committed to providing the best possible service to satisfy our customer's needs, and fulfill our undertaking to deliver top grade products on time and at a competitive price.



Certificate of UL

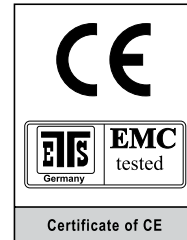

Certificate of CE



Certificate of ISO9001

Our batteries are manufactured to international standards including JIS, DIN and IEC and have UL and CE certification.

Corporate Headquarters and Domestic Sales

Power-Sonic Corporation • 7550 Panasonic Way • San Diego, CA 92154 • USA
Phone: (619) 661-2020 • Fax: (619) 661-3650
Support: technical-support@power-sonic.com
Sales: national-sales@power-sonic.com
Customer Service: customer-service@power-sonic.com

International Sales

Power-Sonic Corporation • P.O. Box 5242 • Redwood City, CA 94063 • USA
Phone: (650) 364-5001 • Fax: (650) 366-3662
Sales: international-sales@power-sonic.com

European Sales

Power-Sonic Europe, Ltd. • 3 Buckingham Square, Hurricane Way • Wickford, Essex SS11 8YQ • England
Phone: (1268) 560686 • Fax: (1268) 560902
Sales: sales@power-sonic.co.uk
Website: www.power-sonic.co.uk

www.power-sonic.com